

●Type A

MANY CARDS CAN BE DISPLAYED.

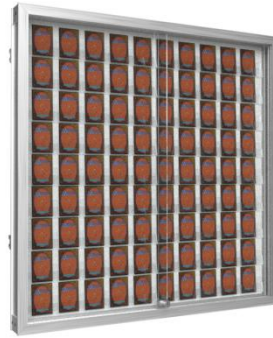

Color: silver

Door: Acrylic board

Frame: Aluminum (silver)

Back board: Alporic board (white)

Card rails: 9 (Vinyl chloride material)

Shipping fee extra

We offer discounts for purchases of 10 units or more!

* This showcase for TCG single card, not for PSA.

●Type B

MANY CARDS CAN BE DISPLAYED.

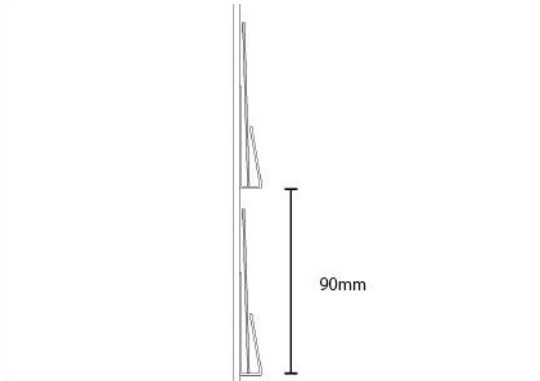

Color: black

Door: Acrylic board

Frame: Aluminum (black)

Back board: Alporic board (black)

Card rails: 9 (Vinyl chloride material)

Shipping fee extra

We offer discounts for purchases of 10 units or more!

* This showcase for TCG single card, not for PSA.

● Type C

BY DISPLAYING THE CARD STANDING UP, IT HAS A THREE-DIMENSIONAL AND LUXURIOUS FEEL.

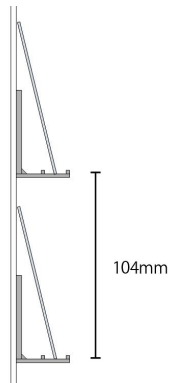

Color: silver

Door: Acrylic board

Frame: Aluminum (silver)

Back board: Alporic board (white)

Card rails: 8 (Acrylic material)

Shipping fee extra

We offer discounts for purchases of 10 units or more!

* This showcase for TCG single card, not for PSA.

● Type D

BY DISPLAYING THE CARD STANDING UP, IT HAS A THREE-DIMENSIONAL AND LUXURIOUS FEEL.

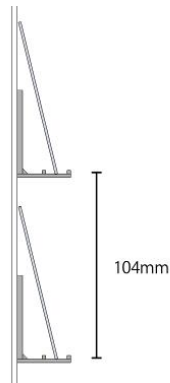
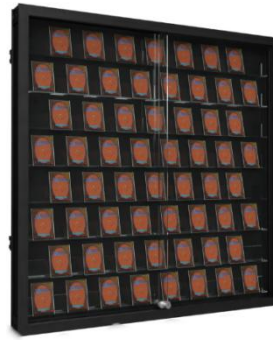

Color: black

Door: Acrylic board

Frame: Aluminum (black)

Back board: Alporic board (black)

Card rails: 8 (Acrylic material)

Shipping fee extra

We offer discounts for purchases of 10 units or more!

* This showcase for TCG single card, not for PSA.

● Type E

PSA GRADED CARDS CAN BE DISPLAYED.

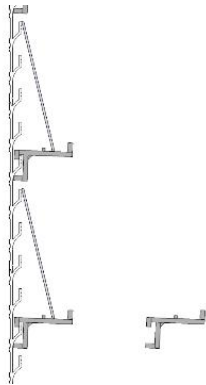

Card rails are removable

Color: silver

Door: Acrylic board

Frame: Aluminum (silver)

Back board: Aluminium shutter panel (silver)

Card rails: 5 (Acrylic material)

Shipping fee extra

We offer discounts for purchases of 10 units or more!

* This showcase is suitable for products of various sizes such as PSA.

● Type F

PSA GRADED CARDS CAN BE DISPLAYED.

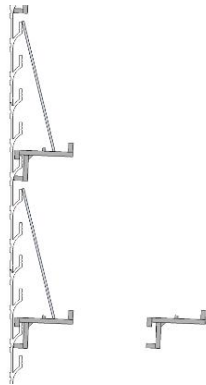

Card rails are removable

Color: black

Door: Acrylic board

Frame: Aluminum (black)

Back board: Aluminium shutter panel (black)

Card rails: 5 (Acrylic material)

Shipping fee extra

We offer discounts for purchases of 10 units or more!

* This showcase is suitable for products of various sizes such as PSA.

● Product details

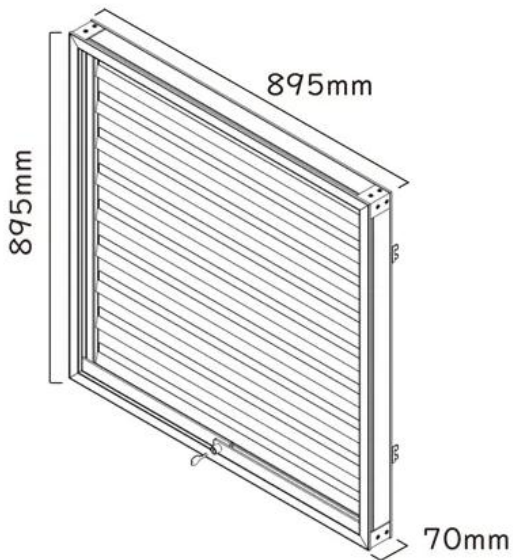

Dimensions: H895 x W895 x D70mm (excluding bracket part)

Weight: 16~20kg

Accessories: Dedicated bracket x 4 pcs Door opening/closing key x 1 pc (1 spare)

Door: Acrylic sliding door

Key: Push cylinder lock

*When displaying expensive items, please consider the [Security Options] at the bottom of the page.

The frame is made of aluminum, which gives it a luxurious feel and is resistant to rust and stains.

● Option

Polycarbonate door

- * High impact resistance, 99.9% UV cut rate, scratch resistance.
- * Separate fee will be charged

POLYCARBONATE Ver.



Will not crack when struck.
Ideal for theft prevention.

Additional Lock -dial type-

- * By installing an additional auxiliary lock, security performance will be strengthened.
- * You can freely set the number using 3 digits.
- * Easy to install with no tools required.



- Gondola Fixtures

Type: Single Sided (For wall mounting) / Double Sided (For island installation)

Color: White/Black

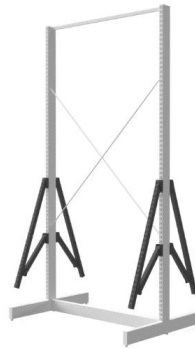
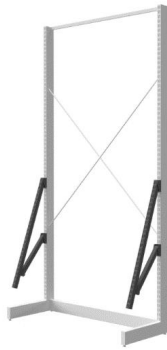

- Single sided Gondola for 2 display
Double sided Gondola for 4 display
- With the option to tilt the lower showcase

※Single Sided Gondola must be grounded to the wall to avoid the risk of tipping over.

● Example 1



Type B 2pcs + Single Sided Gondola 1pc

● Example 2



Type B 4pcs + Double Sided Gondola (Black) 1pc